

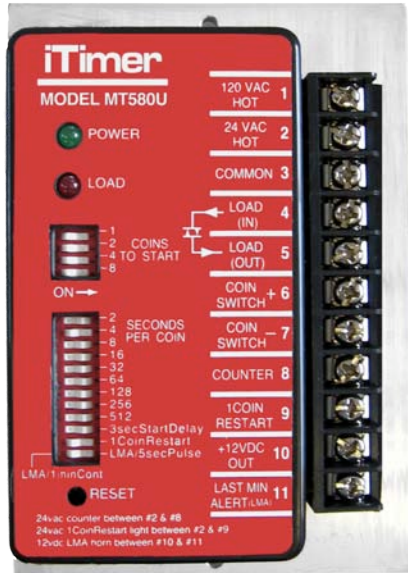

iTimer

BAY & VACUUM ELECTRONIC TIMER



1.0 SWITCH SETTINGS

To set a switch ON, depress the right side of the switch until it clicks into position down. To turn a switch OFF, depress the left side until it clicks into position down.

1.1 COIN SETTING

Set the switches labelled COINS TO START such that they total the number of coins required to start the timer. For example, to start the timer on 3 coins, set switches 1 and 2 on. To start the timer on 6 coins, set switches 2 and 4 on. If all the coin switches are off, the timer will require 16 coins to start.

1.2 TIME SETTING

Set the switches labelled SECONDS PER COIN such that they total the number of seconds per coin that the timer is to operate for. For example, to configure the timer for 30 seconds per coin, set switches 2, 4, 8, and 16 ON. To configure the timer for 40 seconds per coin, set switches 8 and 32 ON. If all the time switches are OFF, the timer will be set for 1 second per coin. The total time that the timer will operate for, once started, is equal to the seconds per coin multiplied by the coins to start. Coins deposited while the timer is operating will result in additional time being added to the total time (each pulse will add the value of the seconds per coin to the time left). The maximum time that may be accumulated is 9 hours, 6 minutes, and 7 seconds (timers with serial numbers previous to 5380 have a maximum accumulated time of 68 minutes and 15 seconds).

1.3 3-SECOND START DELAY

When the switch labelled 3secStartDelay is set ON, the timer will wait for 3 seconds after the required number of coins have been deposited before starting. If this switch is OFF, the timer will start immediately when the required number of coins have been deposited.

1.4 1-COIN RESTART

When the switch labelled 1CoinRestart is set ON, the timer can be restarted with a single coin by depositing a coin at any time within the 20 second time

period after time has expired. Once the 20 second time period has finished, the full number of coins to start the timer is required. The timer will flash a light if attached to the 1COIN RESTART terminal during the 20 second time period to indicate that the timer can be restarted with a single coin. If this switch is OFF, the full number of coins to start the timer will be required once time has expired.

1.5 LAST MINUTE ALERT

The switch labelled LMA/1minCont and LMA/5secPulse determines how a horn or light attached to the LAST MINUTE ALERT terminal functions. When set to LMA/5secPulse, the timer pulses the LAST MINUTE ALERT terminal for 5 seconds when there is 1 minute of time remaining (this setting is typically chosen when a horn is connected to the LAST MINUTE ALERT terminal). When set to LMA/1minCont, the timer turns the LAST MINUTE ALERT terminal on continuously for the last minute of time (this setting is typically chosen when a light is connected to the LAST MINUTE ALERT terminal).

2.0 INDICATOR LIGHTS

The green POWER light on the timer shows that power is being supplied to the timer. The red LOAD light indicates that the timer has been started and that the output to the load is currently being timed.

3.0 RESET

The reset button resets the timer and cancels any existing time. Use a pen or similar object to press the recessed reset button.

4.0 COIN VERIFICATION

A horn connected to the LAST MINUTE ALERT terminal will also provide coin verification. When a coin is accepted, the timer will beep the horn to acknowledge that a coin has been accepted. For electronic coin acceptors that give multiple pulses for a single coin, the horn will beep for each pulse received.

5.0 POWER-UP/RESET STATUS

When power is applied to the timer or the timer is reset by pressing the reset button, the timer indicates that it is operating correctly by sounding the Last Minute Alert horn and flashing the 1 Coin Restart light for 1 second (provided that either a horn or a light are installed).

WITHOUT TRANSFORMER

120VAC LOAD (TYPICAL VACUUM WIRING)

WITH TRANSFORMER

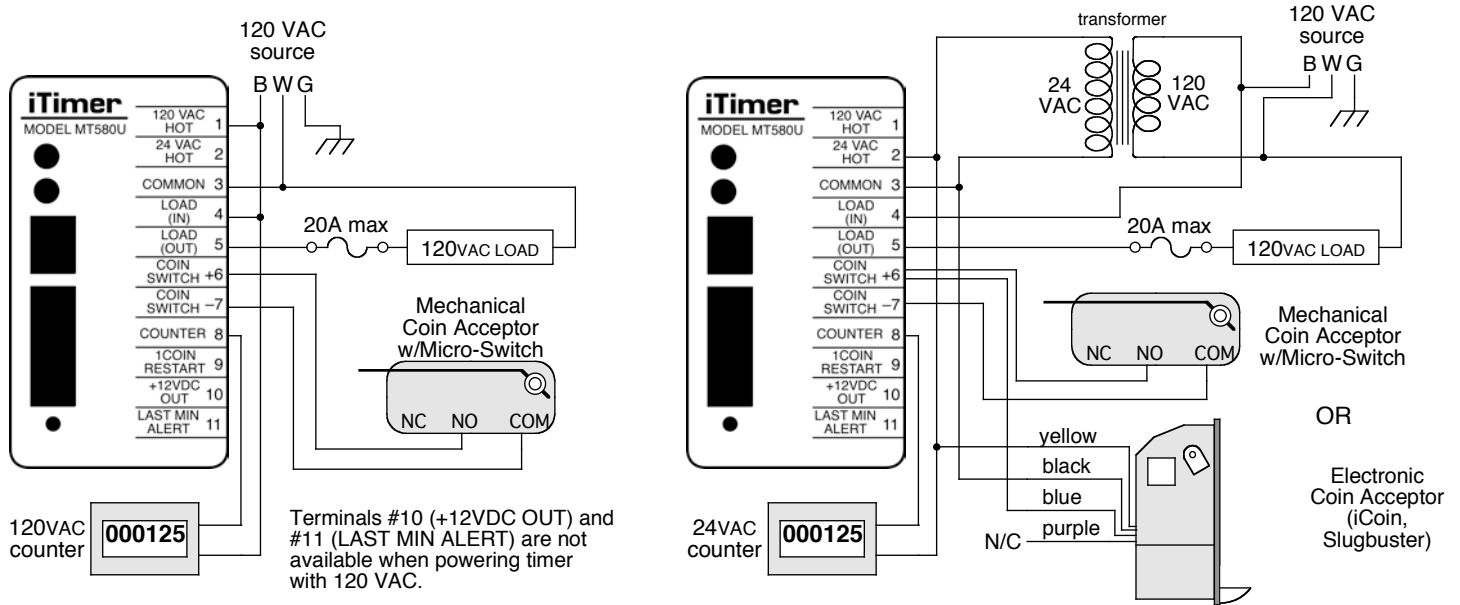

24VAC LOAD (TYPICAL BAY CARWASH WIRING)

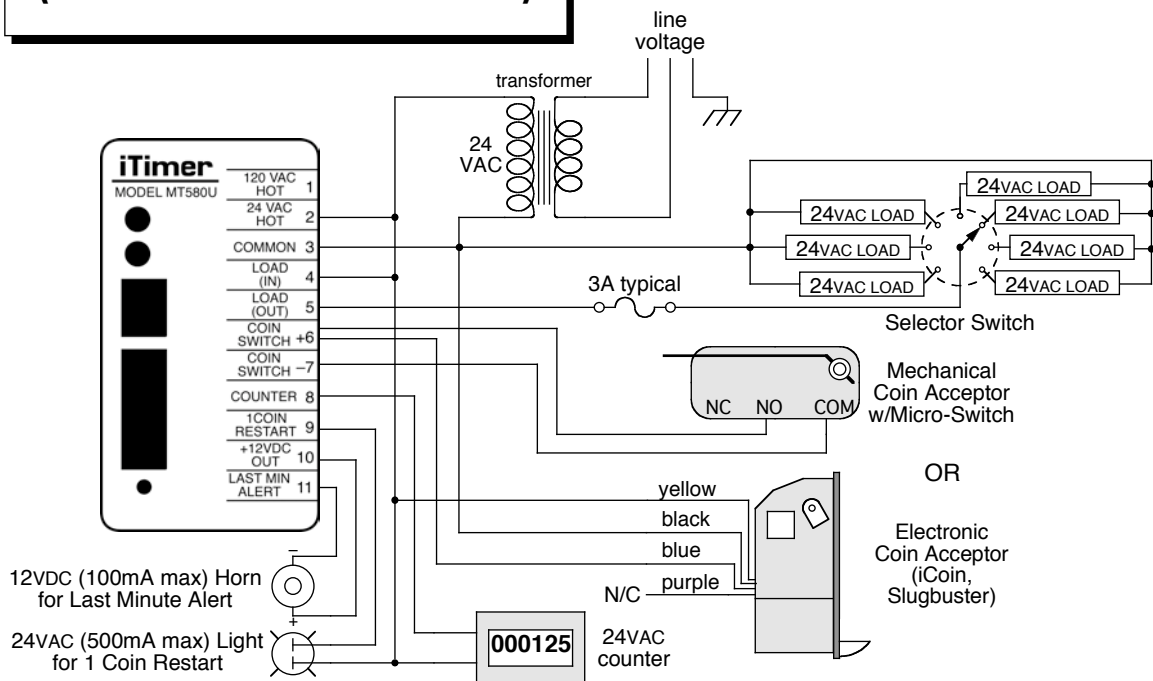

NOTES

- 120VAC LOAD typically is vacuum motor(s).
- 24VAC LOADS typically consist of solenoids, motor starter, etc.
- Load fuse must be installed.
- Always turn power off before servicing any electrical system.
- Back mounting plate of timer should be connected to earth ground.
- Transformer must be Class 2 or fused on secondary.
- Never connect 120VAC to terminal #2. Never connect any power to terminals #7, #10, OR #11.
- All field installations must meet applicable codes.